

Greasing machines **MPD 60-1**, **MPD 60-2**

I. Usage

The MPD models of LubTechnik greasing machines are used as a cost effective and reliable source of pressure lubricant for central lubrication of big machinery and related systems. The LubTechnik machines with dualpipe feeders (MPD 60-2) can be used for lubrication of many lubricated places in heavy duty applications and harsh conditions (mining machines, filling machines, crushers, mills and machines in paint shops, cement factories, brickworks etc.)

II. Description

The LubTechnik MPD greasing machine products consist of the greasing unit, lubricant reservoir, electromotor, gearbox, pressure protector with regulating nut, manometer, electrical switch, electrical grease level indication (MPD 60-2 only), a frame with wheels (MPD 60-1 only) and greasing outlets (one outlet for MPDc 60-1, two outlets for MPD 60-2).

GREASING MACHINE **MPD 60-1**



GREASING MACHINE **MPD 60-2**



Greasing machines **MPD 60-1, MPD 60-2**

Maximum operating pressure	35 MPa
Nominal pressure	25 MPa
Operating pressure regulation range	5 – 35 MPa
Switch pressure regulation range	5 – 25 MPa
Nominal feed volume	200 cm ³ .min ⁻¹
(at +20°C and 395.10-1 mm lubricant penetration)	750 W
Electromotor power	1395 rpm
Electromotor operating speed	operating 380/220V or 500V, 50Hz, custom
Voltage	voltages available, control voltage 220V
Reservoir volume	63 dm ³
Lubricant	grease max. NLGI-3 (consistence level)
Numbers of outlets:	greasing oil 250 to 1200 mm ² .s ⁻¹
model MPD 60-1	1 outlet
model MPD 60-2	2 outlets
Outlets:	connection treat-size M16 x 1,5
model MPD 60-1	connection treat-size M30 x 1,5

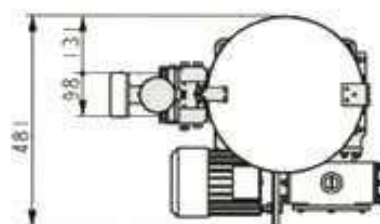
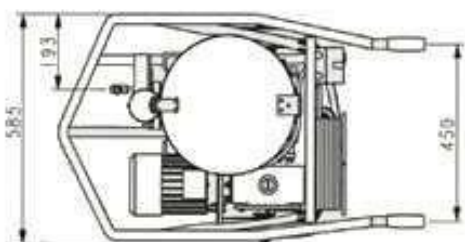
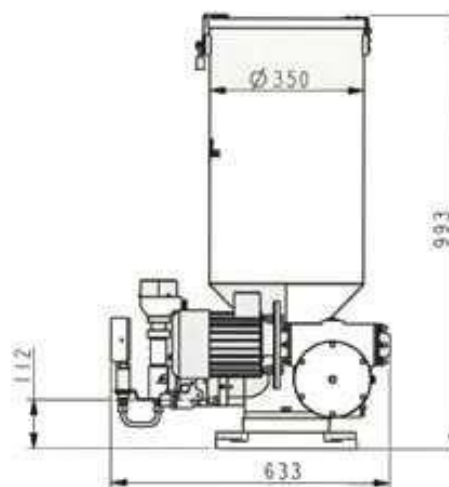
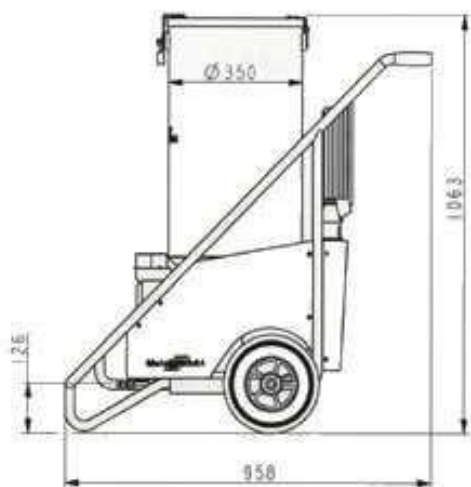

Mechanical Lubricators, Model UV

The UV models of LubTechnik mechanical lubricators are designed for central lubrication of machines with small number of lubricating points of artificial lubricant or oil where the counter pressure of lubricating points including the lubricating tube will not exceed 20 MPa. It has its own reservoir of lubricant.



Mechanical Lubricators, Model UV

CONSECUTIVE NUMBERS OF WORKMANSHIP												
TYPE		INTERNAL GEARING RATIO				DRIVE POSITION VIEW TO THE OUTLETS		DIRECTION OF THE SHAFT ROTATION		ELECTROMOTOR VOLTAGE		
		1:15	1:30	1:3,5	1:8	TO THE LEFT	TO THE RIGHT	LEFT	RIGHT	220V	380V	500V
UVC	01	X				X		X	X			
	02	X					X	X	X			
	03		X			X		X	X			
	04		X				X	X	X			
UVF	01	X				X		X	X		X	
	02	X				X		X	X	X		
	03	X				X		X	X			X
UVB	01			X		X		X				
	02			X		X			X			
	03			X			X	X				
	04			X			X		X			
	05				X	X		X				
	06				X	X			X			
	07				X		X	X				
	08				X		X		X			
UVD	01			X		X		X				
	02			X		X			X			
	03			X			X	X				
	04			X			X		X			
	05				X	X		X				
	06				X	X			X			
	07				X		X	X				
	08				X		X		X			
	09	X				X		X				
	10	X				X			X			
	11	X					X	X				
	12	X					X		X			
	13		X				X		X			
	14		X				X			X		
	15		X					X	X			
	16		X					X		X		

Mechanical Lubricators, Model UV

Nominal pressure	16 MPa
Maximum pressure	20 MPa
Delivered amount for 1 stroke and 1 outlet at counter pressure 16 MPa at 10 strokes/min. and when artificial lubricant is used	0,2 to 0,25 cm ³
The range of dose adjustment of piston stroke	(according to the type of lubricant)
Utilizable range of dose adjustment of piston stroke	0 to 100 %
Recommended number of piston strokes (rev.s of the main shaft)	30 to 100 %
Tank capacity	4 - 10 min-1
Number of outlets	5, 10, 30 dm ³
Internal worm gearing for a drive: - B – swing - C – rotary - D – chain - F – with electromotor	1:3,5 1:8 1:15 1:30 1:3,5 1:8 1:15 1:30 1:15
Output of electromotor	550W (220V, 380V, 500V) 50Hz
Plastic/artificial lubricant of penetration	min. 210
Lubricating oils of viscosity (non guaranteed signaling)	min. 100.10 ⁻⁶ m ² .s ⁻¹
Outlets for the tube – external diameter	10 mm
Angle of lever performance – swing drive	5 to 60°
Maximum number of swings	200 min ⁻¹
Working position	vertical (for oblique contact us)
Ambient temperature	-20 to +55°C

Mechanical Lubricators, Model UV

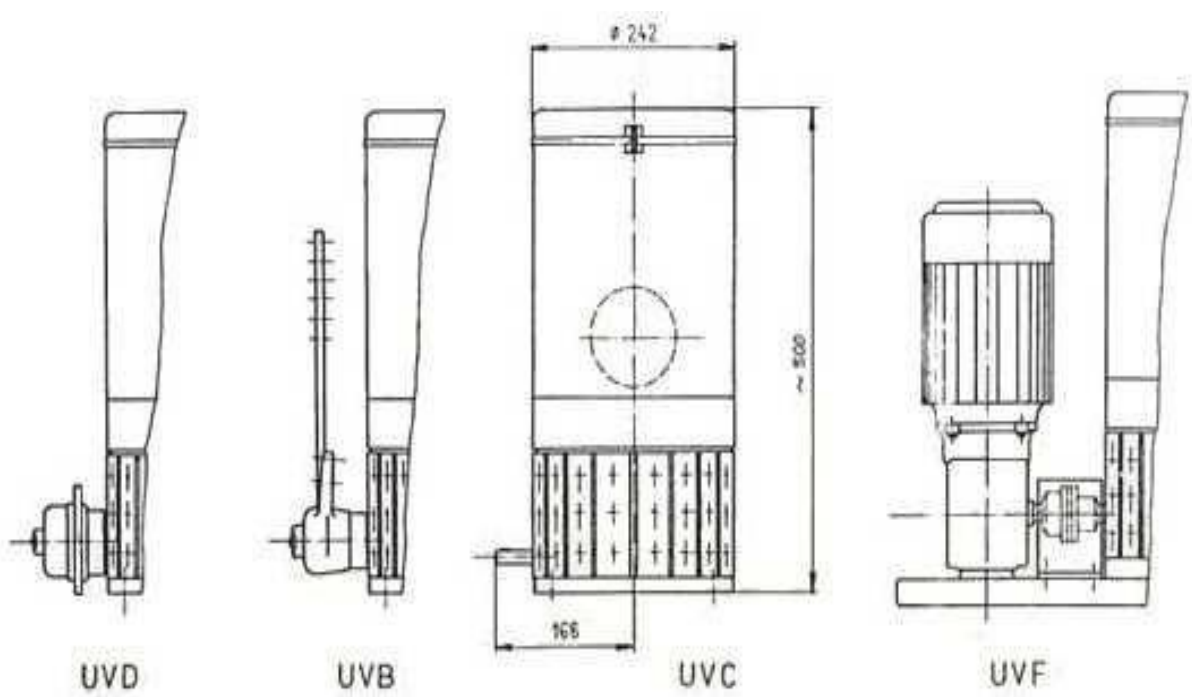
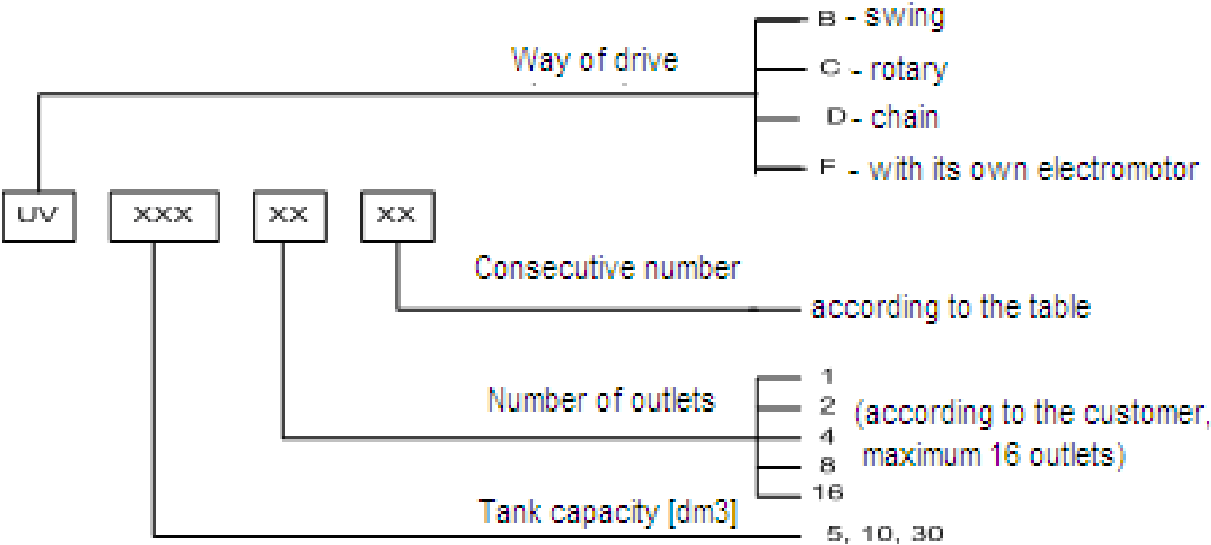

Mechanical Lubricators, Model D

The D models of LubTechnik mechanical lubricators are used to lubricate lubricating points of various machines, e.g. engines, compressors etc. They are equipped with their own lubricant tank..



Mechanical Lubricators, Model D

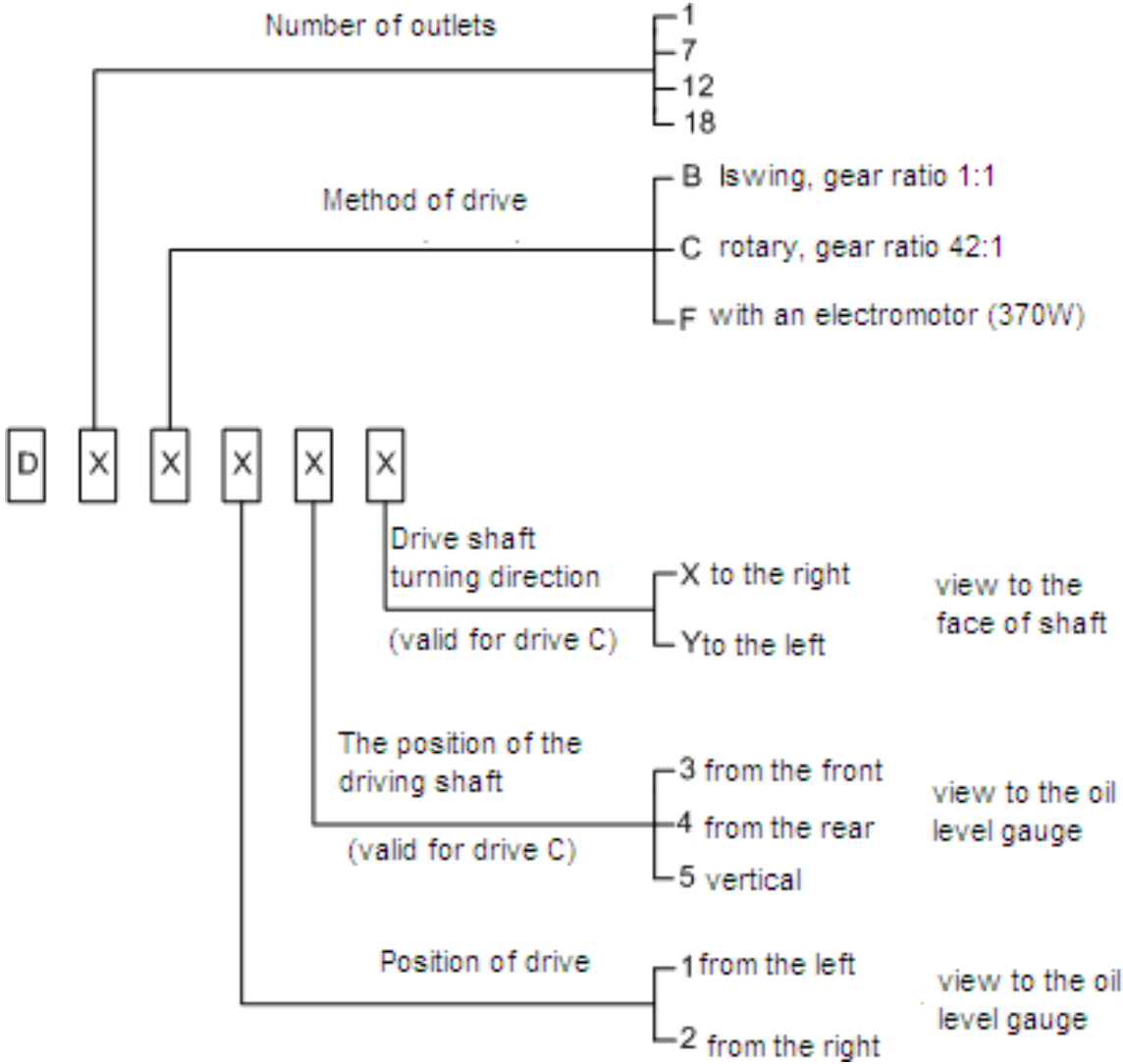

Mechanical Lubricators, Model D

Working pressure in the outlets	2 MPa
Max. supplied amount for 1 stroke of the working piston	0,3 cm ³
Regulation of each outlet	0 – 0,3 cm ³
Outlet threadings for tube external	Ø 8 mm
Mass	2 - 19 kg according to the type
Tank capacity in litres	
D1	1
D7	2
D12, 18	5
Lubricant	lubricating oils of max. viscosity 1000 m ² .s ⁻¹
Normal ambient temperature	+5 to +50°C
At lower temperatures	electrical heating

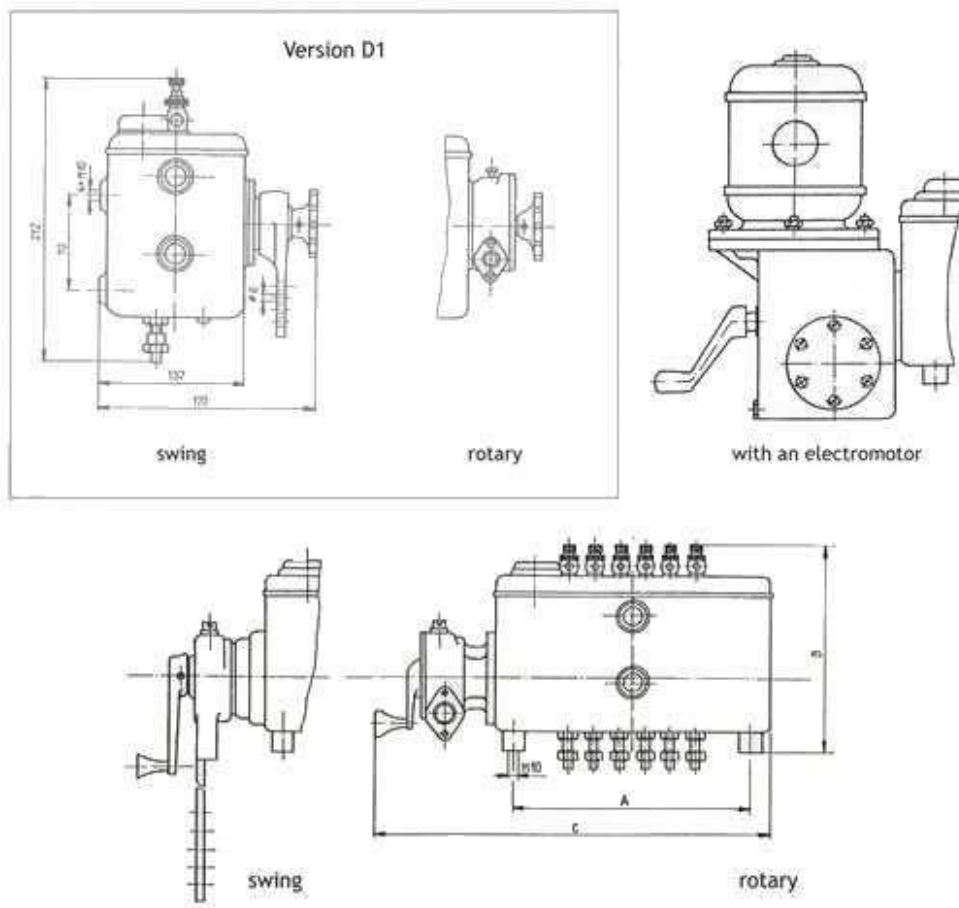

	A	B	C
D 7	150	208	328
D 12	310	208	478
D 18	310	208	478

Mechanical Lubricators, Model **IN**

The IN models of LubTechnik mechanical lubricators are used to lubricate the lubricating points of various machines, e.g. compressors, machine-tools etc. They are not equipped with a lubricant reservoir.



Mechanical Lubricators, Model IN

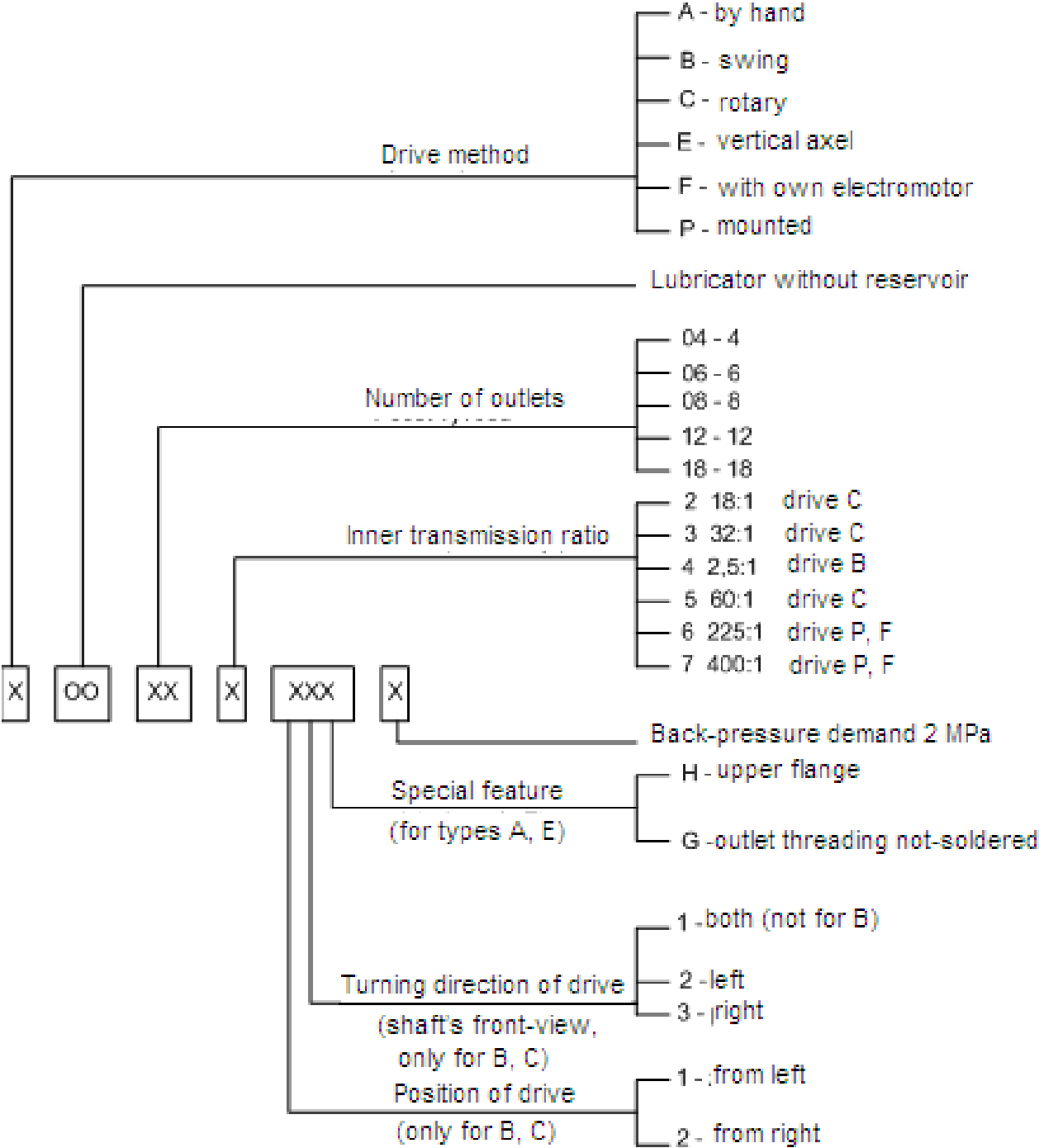

Mechanical Lubricators, Model IN

Max. working pressure in the outlets	1 MPa
Max. working pressure in the outlets (customers request)	2 MPa
Normal lubricant amount supply from one outlet, approx.	0,3 – 1 cm ³ .min ⁻¹
Lubricant amount regulation (always for a pair each other)	according to revolutions
Lubricant	0; 30 - 100 %
Maximum suction height / max. length of suction piping	lubricant oils of max. viscosity 1000 m ² .s ⁻¹
Connecting threading of the suction piping	2m / 3m
Connecting threading of the lubrication piping	for tube Ø8
Central shaft revolutions range	for tube Ø4, Ø3
The swing of swing drive's lever	3 – 10 rpm
Number of outlets	5 - 60°
Mass approx.	5, 6, 12, 18
Working position	2 – 3,5 kg

