

## MSP Modular Divider Valves

*Your key to  
maximum  
design  
flexibility  
with series-  
progressive  
reliability.*



## Match lubricant flow to the exact needs of each point.

- Precise monitoring, positive feedback
- Simple to install and operate
- Modular design for total flexibility

### THE FLEXIBLE, MODULAR MSP DIVIDER VALVE

- For grease or oil systems up to 3,500 psi (241 bar)

- Lubricate up to 16 points per valve assembly
- Choice of SAE, NPSF, or BSPP inlet/outlet connections
- O-ring sealing prevents leaks, reduces maintenance
- Individual valve outputs vary by a maximum ratio of 16:1

- Built-in check valves prevent lube re-entry and help keep lines full
- Stackable design simplifies installation, adds flexibility
- Available in carbon steel with standard yellow zinc dichromate plating. Contact Lubriquip's factory regarding 316 stainless steel for corrosive applications.

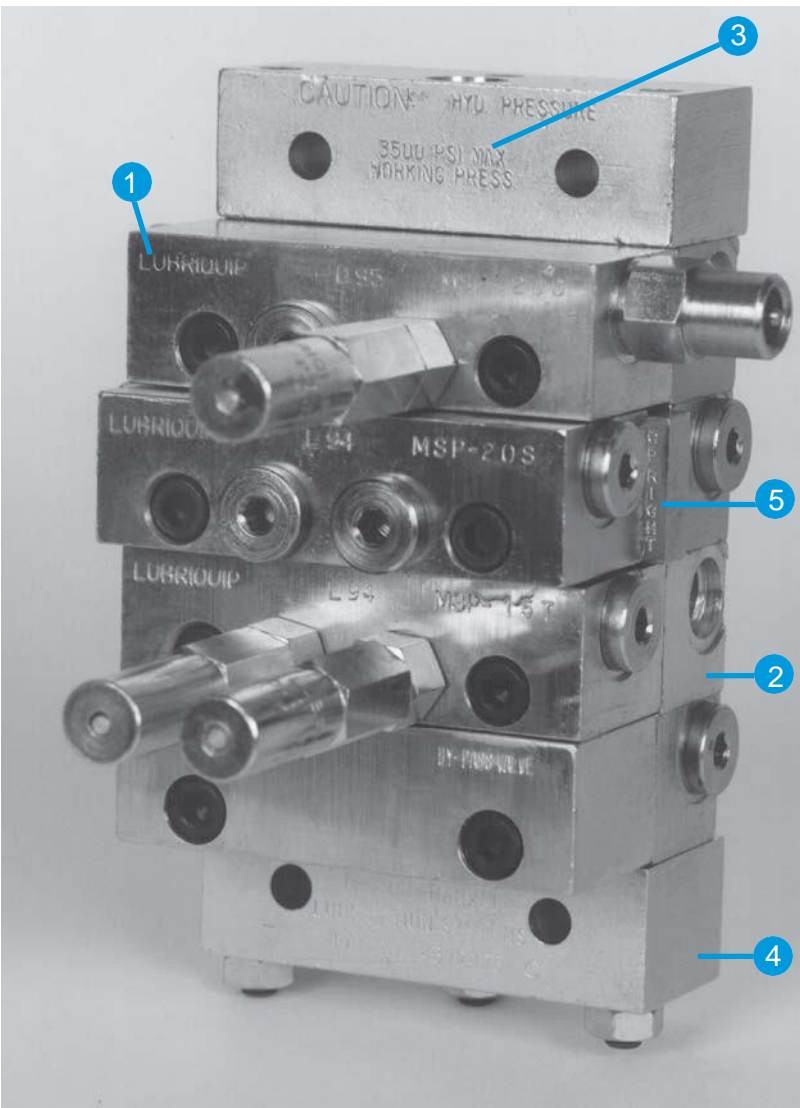

Each assembly includes: (1) *valve sections* with working piston (3 minimum), (2) *subplates* with outlet ports, (3) *inlet* section, and (4) *end* section.

*Twin* piston sections are ported to create *separate outputs* for two lube points. *Single* sections *combine* the output from both ends of the piston and send it to a single lube point.

Field-installable *crossport* or *singling* plates (5) may be used to increase the flow to a single point or accommodate an odd number of lube points.

A *bypass section* is available to eliminate a piston section or provide for added lube points in the future.

**NOTE:**

When bypass sections are used, the Divider valve assembly must have a minimum of 3 working sections in addition to one or more bypass sections.

# Improve matchup of lube delivery and machine usage.

## SPECIAL INLET SECTIONS

- Allow zoning of large systems served by single pump and reservoir
- Choice of inlet port activation: electric or pneumatic
- Simpler to install, add or remove points
- Choice of SAE, NPSF, BSPP (ISO 1179) metric (ISO 6149) connection

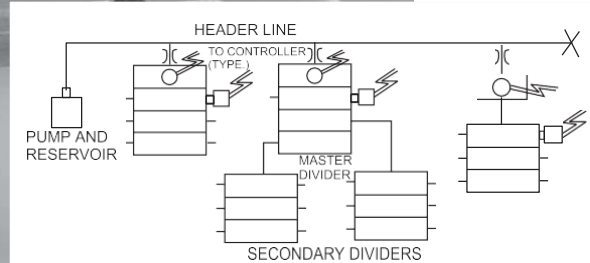

These versatile inlets provide positive, series-progressive lubrication for extended lines and systems. You easily match lube delivery to machine usage, bypass machinery that's not currently in use, and get reliable start-up testing, monitoring, and fault detection.

**Reversing Inlet Section.** Hydraulically activated, it is used with a separate, hydraulically-controlled reverser valve to serve large zoned systems without need for electrical solenoid valves.

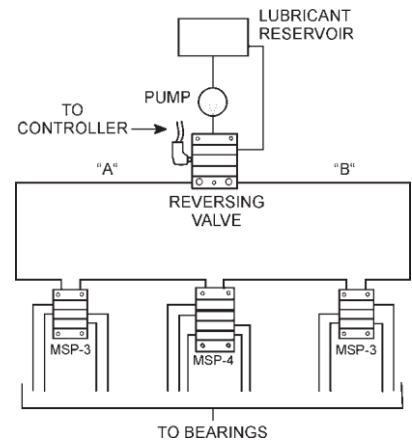
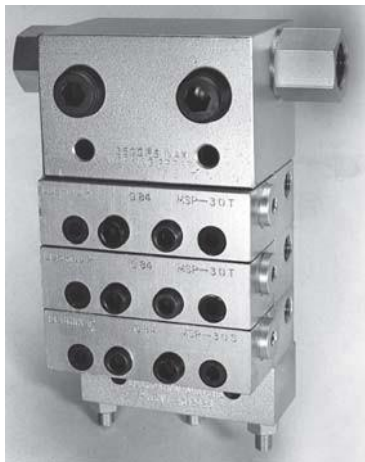

**Shunt Inlet Section.** A three-function valve, either electric or pneumatic, (1) Allows lubricant to enter divider valve, (2) bypasses it to another divider valve, or (3) diverts it back to tank. Replace standard inlet or mount in-line with remote manifold kit.

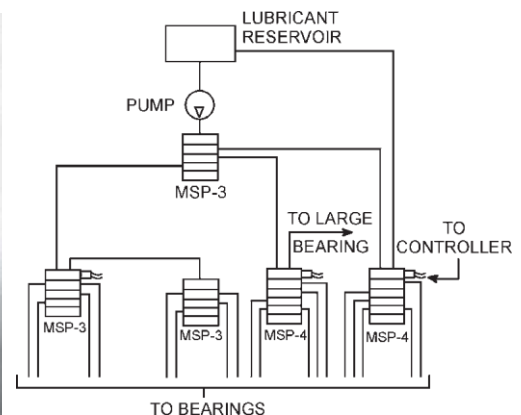
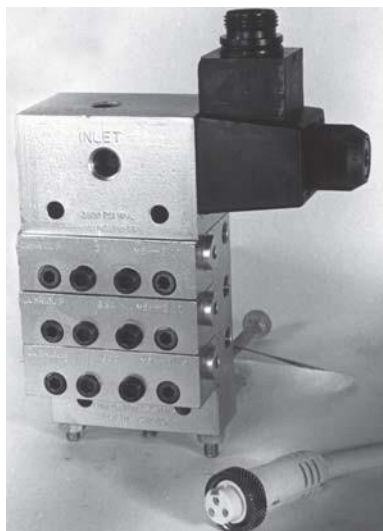

# A wide variety of safeguards monitor and verify lube cycles.

- Track valve-piston action
- Easily interfaced to system controller

## CYCLE INDICATORS

These mechanical and electrical units sense the divider valve piston's action for accurate control and monitoring of lube cycles.

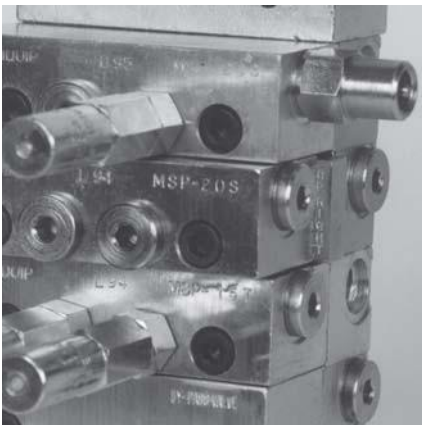

- **Cycle Indicator Pin.** Valve sections are available with a factory-installed indicator pin which moves in and out as lubricant passes through the valve.
- **Universal Cycle Counter.** Six-digit counter displays each complete cycle of the divider valve. Requires divider valve section with indicator pin (described above).  
Part number: **527-002-410.**



- **Magnetic Visual Indicator.** Six steel balls in a clear sleeve follow a magnet which moves with the cycling piston, providing a clear visual indication of lube cycles. Part number: with "O" ring, **509-932-522.**



- **Cycle Indicator Switch (SPDT).** Used in conjunction with the cycle indicator pin at cycle rates not exceeding 60 cpm, it provides an electrical signal to the system controller which counts cycles to monitor and verify completion of the lube cycle. Part number: **510-599-000.** A moisture-resistant switch, **510-599-200,** is also available.



- **LED Field-sensitive Proximity Switch.** This 24 VDC device magnetically senses the movement of the piston, triggering the switch and illuminating the LED. Part numbers: 3-pin with "O" ring, **527-005-690;** 5-pin with "O" ring, **527-005-670;** Explosion proof with "O" ring; **527-006-060.**

- **Field-sensitive Proximity Switch.** A ceramic-magnet switch for grease or oil systems up to 200 cpm at pressure up to 3,500 psi (241 bar), accurately signals piston cycles, and is ideal for high-cycle applications. Part numbers: 3-pin with "O" ring, **527-003-251;** 5-pin with "O" ring, **527-004-111.**

- **Connecting Cables.** Brad Harrison mating cables with either 3- or 5-pin connectors are available in 12-ft. (3.65 m) lengths for the F/S proximity switches and other devices. Refer to **bulletin 15600** for complete listing of proximity cycle switches.

# Choice of indicators offer automatic system protection and fault location.

- Immediate response to blockages
- Manual or automatic reset
- Continues to serve unaffected points

## PERFORMANCE INDICATORS

These vital safeguards react to excess lube pressure when points or lines become blocked. Installed in indicator ports on the working piston sections, they quickly identify the affected lines. Refer to **bulletin 15401** for complete listing of available performance indicators.

- **Automatic Relief-to-Atmosphere Indicator (O-Ring Seal).**

Spring-loaded piston unseats when blockage occurs, venting lubricant to atmosphere each time piston cycles. This allows system to lubricate unaffected points. When the blockage is cleared, the indicator reseats automatically.

- **Manual Reset Indicator with Memory (O-Ring Seal)**

System blockage triggers a spring-loaded piston to display an indicator. Since there is no relief, pressure backs up in the system and the system stops, allowing a controller to alarm. After correcting the problem, the indicator pin is reset manually.

Part Number (O-Ring)	Relief Pressure
508-310-415	750 psi (51 bar)
508-310-425	1,000 psi (69 bar)
508-310-435	1,250 psi (86 bar)
508-310-445	1,500 psi (103 bar)
508-310-455	2,000 psi (138 bar)
508-310-465	2,500 psi (172 bar)
508-310-475	3,000 psi (207 bar)

Part Number (O-Ring)	Relief Pressure
509-932-590	250 psi (17 bar)
509-932-600	500 psi (34 bar)
509-932-610	750 psi (51 bar)
509-932-620	1,000 psi (69 bar)
509-932-630	1,500 psi (103 bar)
509-932-640	2,000 psi (138 bar)
509-932-650	2,500 psi (172 bar)
509-932-590	3,500 psi (241 bar)



Automatic Relief-to-Atmosphere Indicator



Manual Reset Indicator with Memory

# Designed with over 100 years experience in centralized lubrication.

- Engineering certified to ISO 9001 Standards
- Modular design for maximum flexibility
- Install and maintain without disturbing lube lines

## QUALITY DESIGN

### SIDE VIEW

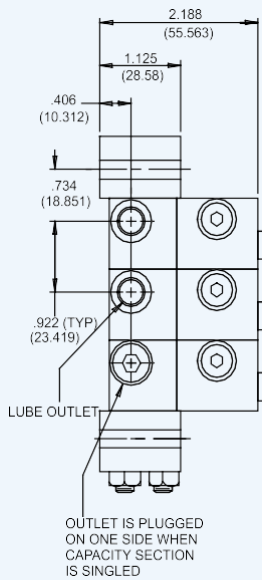

### TOP VIEW

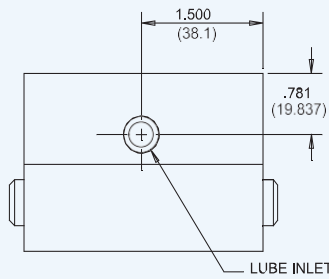

### FRONT VIEW

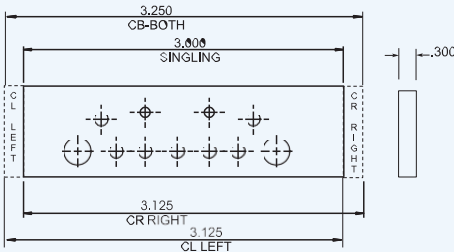
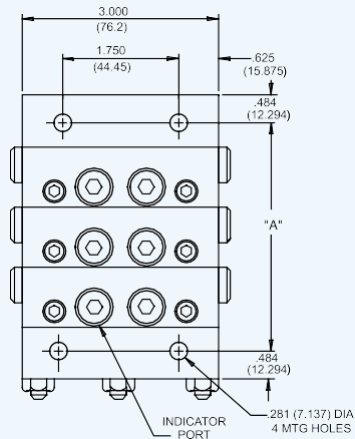

#### PRODUCT I.D.

STYLE	TAB(S)
CR RIGHT	RIGHT
CL LEFT	LEFT
CB-BOTH	RIGHT & LEFT
SINGLING	NONE

QTY. OF SECTIONS	"A"
3	3.578 (90.881)
4	4.500 (114.30)
5	5.422 (137.718)
6	6.344 (161.138)
7	7.266 (184.556)
8	8.188 (207.975)

## MSP DIVIDER SPECIFICATIONS

Standard Material .....Corrosion Protected Steel  
 Optional Material..... Type 316 Stainless Steel  
 O-Ring Seals..... (Standard) 70 Durometer Buna-N  
 (Optional) 70 Durometer Viton

#### Maximum Cycle Rate:

(with Cycle Pin) ..... 60 CPM  
 (w/o Cycle Pin, or w/Prox Cycle Sw..... 200 CPM

Pressure (max.)..... 3,500 psi (241 bar)

Temperature (max.) .....Buna-N Seals 200°F (93°C)

Viton Seals 350°F (177°C)

Lubricant .....Oil or Grease

#### Zero Leak Inlet

Pressure (max.) .....1500 psi (104 bar)

Ambient Temperature (max.) ..... 140°F (60°C)

Lubricant (oil only)..... up to 5000 SUS

Requires 25 micron (min) filtration

Electrical Characteristics ..... See Page 7

#### Shunt/Shut-off Inlet

Pressure (max.) .....3000 psi (207 bar)

intermittent supply pressure only

Ambient Temperature (max.)..... 140°F (60°C)

Lubricant..... Oil and fluid grease

filter oil through 25 micron filter and

grease through a 100 mesh strainer.

Electrical Characteristics..... See Page 7

#### Net Weight

		Lbs.	(kg)
3-section	Divider Valve Assembly	5.9	(2.7)
4-section	" " " " "	7.3	(3.3)
5-section	" " " " "	8.7	(4.0)
6-section	" " " " "	10.2	(4.6)
7-section	" " " " "	11.6	(5.6)
8-section	" " " " "	13.0	(5.9)

## TORQUE SPECIFICATIONS

Tie Rod Nut	5-8 Ft. Lbs.
Valve Block Mtg. Screw	8-9 Ft. Lbs.*
Indicator Port Plug	8-9 Ft. Lbs.*
Inlet Bleed Screw	1-2 Ft. Lbs.
Piston Enclosure Plug	12-15 Ft. Lbs.*

\* O-Ring sealed components

## ZERO LEAK INLET SHUT-OFF VALVE

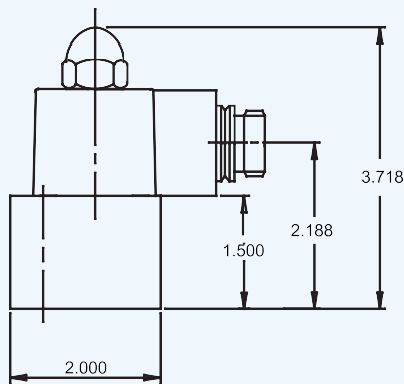
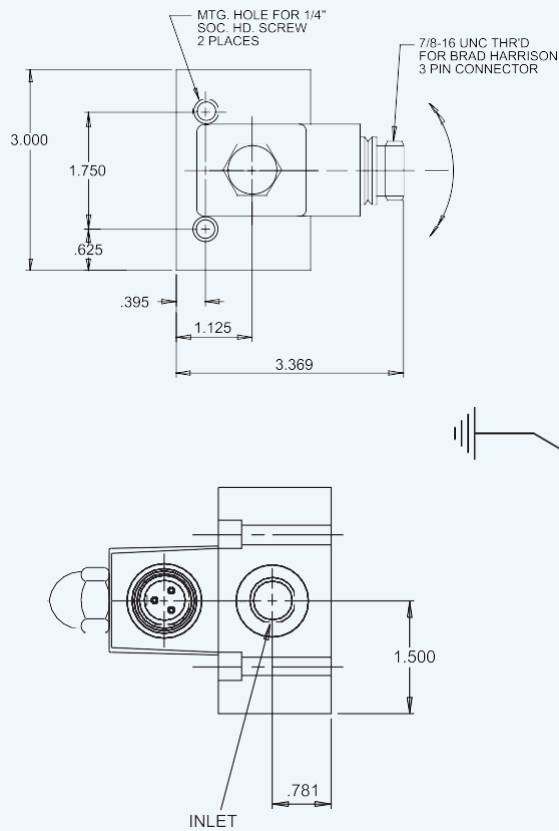

**ZERO LEAK ELECTRICAL SPECIFICATIONS**  
115 VAC, .22 A IN-RUSH, .14 A HOLDING  
24 VDC, 28 W

## SHUNT INLET OPTION

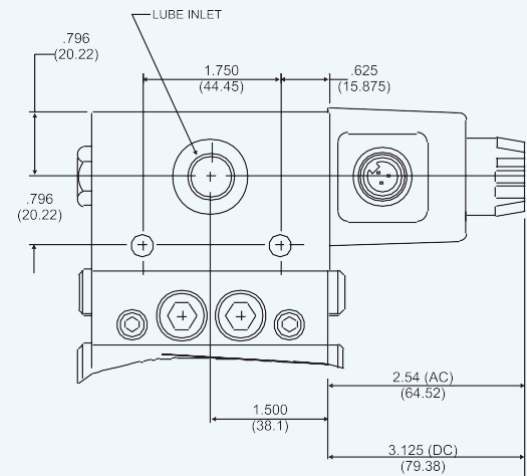
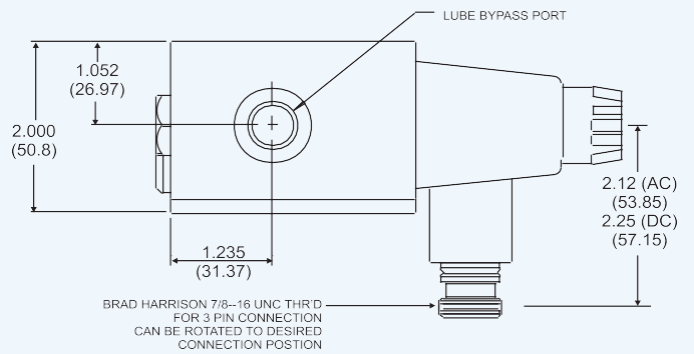

### SHUNT/SHUT-OFF ELECTRICAL SPECIFICATIONS

115 VAC, 1.6 A IN-RUSH, .54 A HOLDING

24 VDC, 28 W.

SOLENOID MOUNTED ON RIGHT SIDE N.O.

TO DIVIDER, CLOSED TO BYPASS.

SOLENOID MOUNTED ON LEFT SIDE N.C.

TO DIVIDER, OPEN TO BYPASS

## REVERSIBLE FEEDER INLET

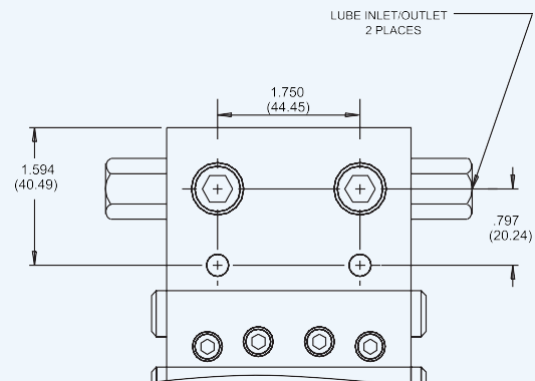

# You can easily configure the system to the need.

- Custom performance from stock modules
- Choice of Single or Twin outlets

## SPECIFYING GUIDE - MSP DIVIDER VALVE

### Component Identification and Ordering Information\*

#### Zinc plated carbon steel

Parts List Key	Size	Description	Displacement in. <sup>3</sup> cm <sup>3</sup>	Buna-N Seal Part No.	With Cycle Pin (Rt. Side) Buna-N Seals Part No.
1		Valve Sections			
	5T	.005 Twin Outlet	0.005 0.082	106-100-175	
	5S	.005 Single Outlet	0.010 0.164	106-100-015	
	10T	.010 Twin Outlet	0.010 0.164	106-100-185	
	10S	.010 Single Outlet	0.020 0.328	106-100-025	
	15T	.015 Twin Outlet	0.015 0.246	106-100-195	
	15S	.015 Single Outlet	0.030 0.492	106-100-035	
	20T	.020 Twin Outlet	0.020 0.328	106-100-205	106-100-935
	20S	.020 Single Outlet	0.040 0.656	106-100-045	106-100-735
	25T	.025 Twin Outlet	0.025 0.410	106-100-215	106-100-945
	25S	.025 Single Outlet	0.050 0.820	106-100-055	106-100-745
	30T	.030 Twin Outlet	0.030 0.492	106-100-225	106-100-955
	30S	.030 Single Outlet	0.060 0.983	106-100-065	106-100-755
	35T	.035 Twin Outlet	0.035 0.574	106-100-235	106-100-965
	35S	.035 Single Outlet	0.070 1.148	106-100-075	106-100-765
	40T	.040 Twin Outlet	0.040 0.656	106-100-245	106-100-975
	40S	.040 Single Outlet	0.080 1.311	106-100-085	106-100-775

Parts List Key	Description	Part Number
8 (3 Req'd)	Tie Rod & Nut Assembly	_____
	3 Section	527-001-930
	4 Section	527-001-940
	5 Section	527-001-950
	6 Section	527-001-960
	7 Section	527-001-970
	8 Section	527-001-980
9	Tie Rod Nut Only	410-440-010
10	Valve Block Mounting Screws	419-140-070
11	Piston Enclosure Plug	527-000-232
12	Piston Enclosure "O" Ring	422-210-040
13	Indicator Port Plug	527-300-840
14	Indicator Port Plug "O" Ring	422-210-030
15	MSP Buna-N "O" Rings MSP (70 Duro) Viton "O" Rings	422-010-060 527-000-810
16	Valve Block Mounting Screw for Crossport/Singling Plate	419-140-080
17	Outlet Check Ball	401-030-020
18	Outlet Check Spring	527-001-910

Parts List Key	Description	1/8-27 NPSF Part No.	7/16-20 SAE Part No.	1/8-28 BSPP Part No.
2	Subplate	527-000-311	527-003-550	527-003-140

Parts List Key	Description	1/4-18 NPSF Part No.	7/16-20 SAE Part No.	1/4-19 BSPP Part No.
3	Inlet	527-001-800	527-003-540	527-003-130
	Inlet w/Bleed	527-000-321	527-000-325	_____
4	End Section	527-001-900	527-001-900	527-001-900
†	End (SPP)	510-770-332	510-770-332	510-770-332
5	Crossport Plate			
	Right	527-005-320	527-005-320	527-005-320
	Left	527-005-330	527-005-330	527-005-330
	Both	527-005-340	527-005-340	527-005-340
6	Singling Plate	527-005-350	527-005-350	527-005-350
7	Bypass Block	106-000-010	106-000-010	106-000-010

**NOTE:** Part numbers shown are for standard plated steel with Buna-N Seals. Consult Lubriquip for Viton Seals, or stainless steel components.  
Valve sections with cycle pin are standard Right Hand; can be made Left Hand. Consult factory. Consult factory for components requiring thread connection series other than those listed.

† End Section (SPP) is supplied with plugged 1/8-27 NPS manual lube fitting port. Order 412-700-490 manual lube fitting separate.

\*\* Reversing inlet has 3/8" NPSF or 3/8" BSPP ports.

++ ISO 1179 Port

## SPECIAL INLETS

Description	Valve State	1/4-18 NPSF Part No.	9/16-18 SAE Part No.	1/4 BSPP Part No.
Zero Leak, 115 VAC, 3-pin Brad Harrison Connector Replacement Coil	N.C.	527-004-320	527-005-200	_____
	_____	492-120-149	492-120-149	492-120-149
Zero Leak, 24 VDC, 3-pin Brad Harrison Connector Replacement Coil	N.C.	527-004-870	527-005-180	463-920-720
	_____	492-120-154	492-420-154	492-120-154
Zero Leak, No Coil Order Separate	_____	_____	_____	527-004-770
Shunt/Shut-Off, 115 VAC, 3-pin Brad Harrison Connector Replacement Coil	N.O. N.C.	527-003-660 527-003-670	527-004-790 527-004-800	_____
	_____	492-120-128	492-120-128	492-120-128
Shunt/Shut-Off, 24 VDC, 3-pin Brad Harrison Connector Replacement Solenoid	N.O. N.C.	527-003-680 527-003-690	527-005-780 527-005-785	527-007-090 ++ 527-007-100 ++
	_____	492-120-130	492-120-130	492-120-130
Shunt/Shut-Off Pneumatic Operator	_____	527-003-730	_____	_____
Remote Manifold Kit for Zero Leak and Shunt/Shut-Off	_____	527-004-360	527-005-400	_____
Reversing Inlet	_____	527-002-740 **	527-005-370	527-004-100 **
Shunt/Shut-Off 110 VAC/50 hz Hirschmann Connector Replacement Coil	N.O. N.C.	527-004-090 * 527-004-310	_____	_____
	_____	492-120-137	492-120-137	492-120-137
Shunt/Shut-Off 220 VAC/60 hz Hirschmann Connector Replacement Coil	N.O. N.C.	527-003-260 * 527-003-270 *	_____	_____
	_____	492-120-131	492-120-131	492-120-131

# Modular design for full flexibility.

- One valve assembly serves up to 16 points
- “O” ring sealing throughout prevents leakage
- Built-in check valves prevent lube re-entry and help keep lines full

## MSP DIVIDER VALVE

### Parts List Schematic

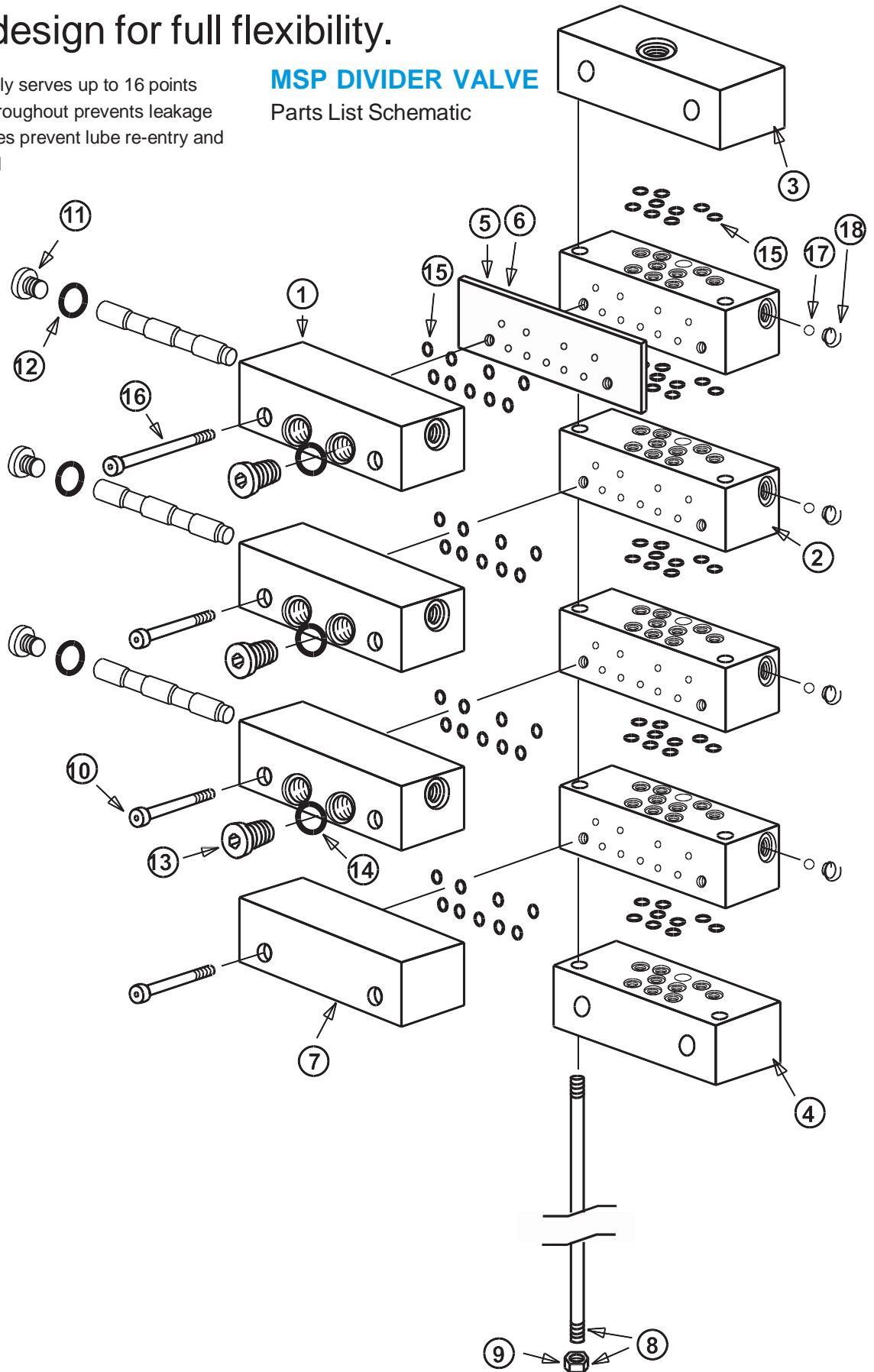

# How to Order

## ORDERING INFORMATION

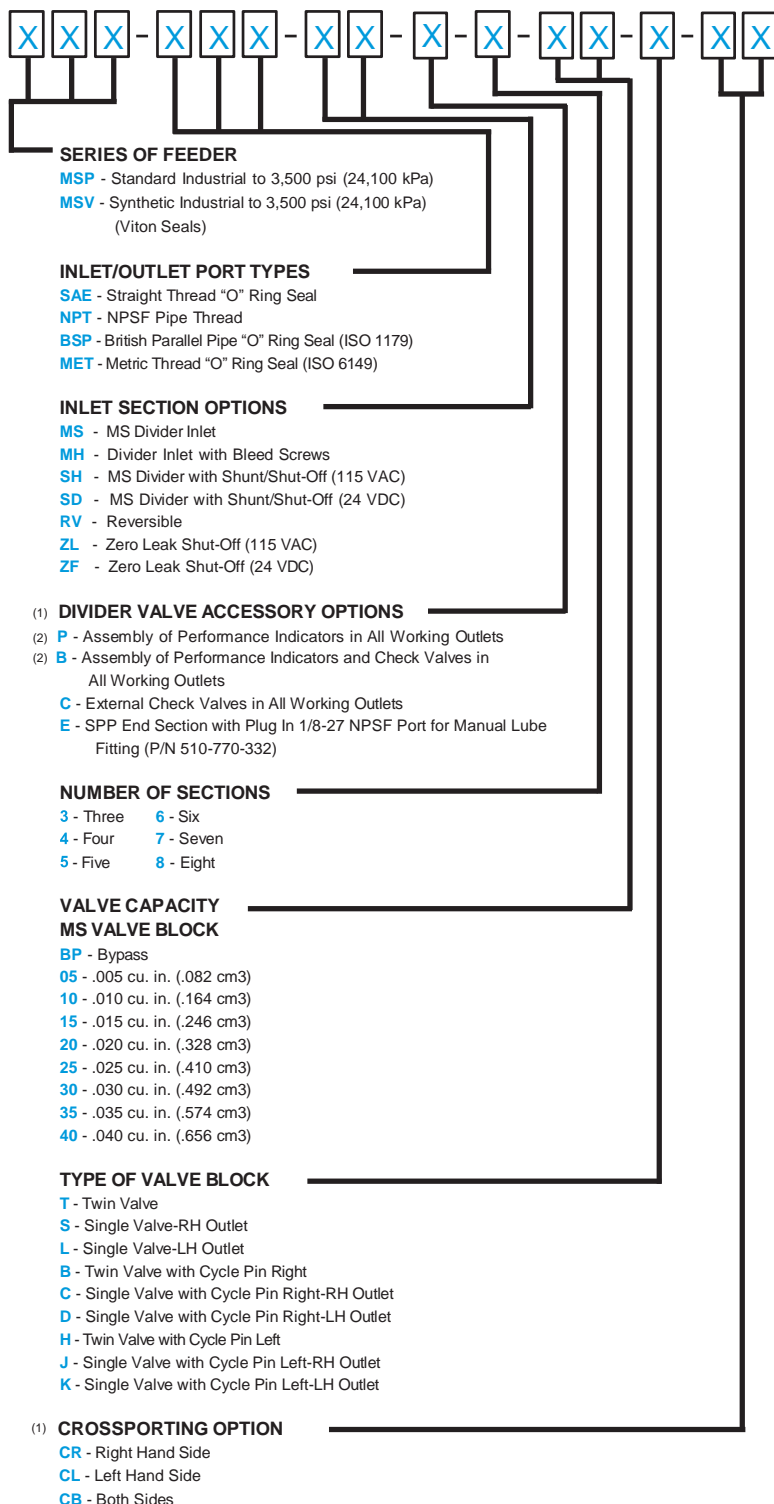

**NOTES:**

- (1) Omit when not required.
- (2) Specify part number, or type and pressure rating to be supplied.
- (3) Specify part number, or type, voltage and connector style to be supplied.

## NOTES

1. Right/Left Hand determined when viewing front of divider valve assembly. (Divider valve assembly placed on flat surface with inlet at top.)
2. Valves are specified starting from inlet section.
3. When valve is crossported, its outlet is plugged and output is diverted to next valve away from inlet.
4. Last valve in divider assembly, farthest from inlet, cannot be crossported.
5. Single valve can be crossported on one side only.
6. When valve is a single, only one outlet in its subplate can be used, other outlet must be plugged.
7. Cycle pins are available on MS (20, 25, 30, 35, and 40) valves only.
8. All divider valve assemblies must have a minimum of 3 working valves.
9. Bypass block cannot be supplied on divider valve with 3 subplates. Bypass block is not a working valve.
10. Divider systems should be limited to first and second stages only. Third staging is not recommended. Refer to Trabon **Bulletins 20101, 20105 and 20115** for further information on system design.

## ORDERING EXAMPLE

5-section MSP Divider Valve Assembly, standard seals, SAE ports and performance indicators in each working outlet. Consisting of:

- 1 - .030 Twin Valve with Cycle Pin Right Side
- 1 - .040 Single Valve - Crossport Right Side
- 1 - .040 Single Valve - Right Hand Outlet
- 1 - .020 Twin Valve
- 1 - Bypass Block

Ordering Code - MSP-SAE-MS-P-5-30B-40SCR-40S-20T-BP

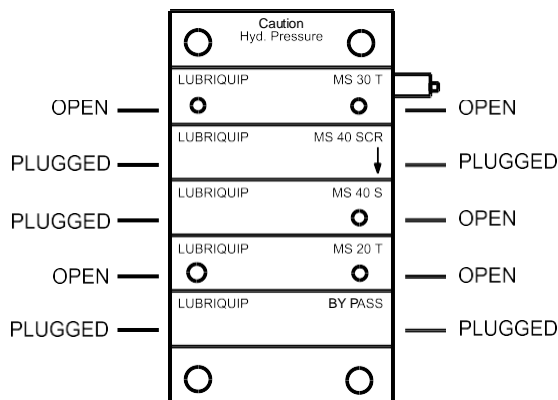

# LUBRIQUIP® has applied automatic lubrication technology to a world of needs including yours!



Lubriquip systems require minimum attention. Filling the reservoir and periodic inspections are the only routine maintenance required.

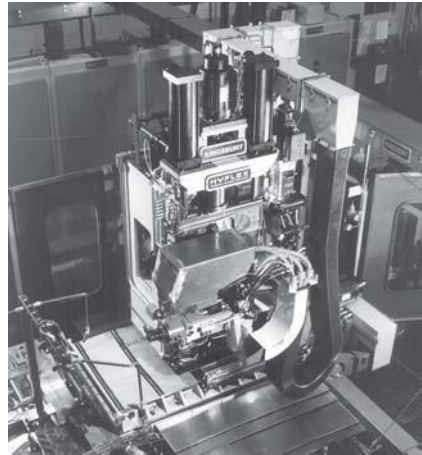

Automated systems improve safety. Maintenance personnel do not have to lubricate dangerous machinery. Operators have less exposure to oil and lubricants on equipment and floor.



Lubriquip's precise lubricant delivery eliminates lubricant waste, product contamination and heat buildup from excessive viscous shear.

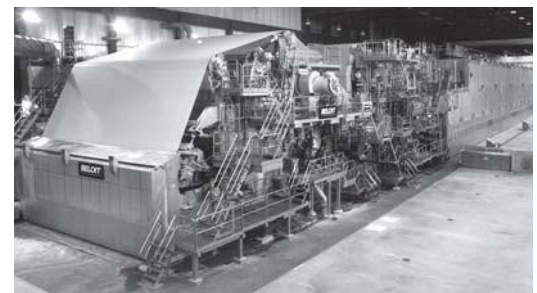

Lube delivery to machines in motion is often superior to static lubrication. Oil and grease are forced into the load area to coat wear points.

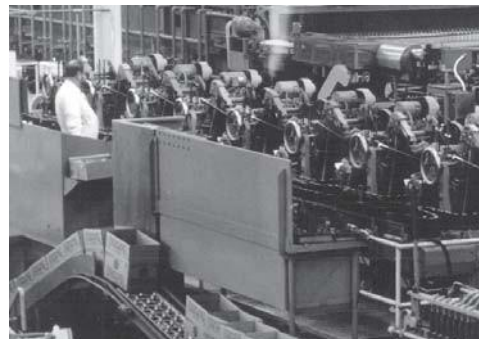

Surges, vibration, and other erratic operations are reduced with automatic lube systems. This minimizes risk of damage to equipment, products and personnel.



Lubriquip's automated systems deliver lubricant to vital mechanisms, prolonging equipment life and reducing downtime.

All Lubriquip systems are engineered for the machinery and lubricant being used. We can even supply the lubricant, matched to the system you need.



## Your solution is at hand.



Our years of engineering innovative lubrication technology, plus our worldwide network of more than 100 distributors means that the components you need are probably in stock right now. This inventory of proven components allows distributors and factory engineers to design a truly customized system using economical on-the-shelf parts.

### NEW OR UPGRADE, LUBRIQUIP HAS THE APPLIED TECHNOLOGY.

Whether you are considering new equipment or upgrading an existing system, count on Lubriquip for the applied lubrication technology to meet your need with a minimum of hassle and investment. Call on our unparalleled customer support for fast efficient design, installation, maintenance and troubleshooting assistance, or to get the name of your nearest full-line, factory-trained distributor.

